

13.5 EuroSenz™

For additional information, please refer to the Instruction Manuals CD shipped with this product, or visit our website at www.emersonprocess.com/raihome/liquid/.

SPECIFICATIONS

ORP Range: -1500 to 1500 mV

Wetted Materials: Polypropylene, EP, Glass, and Platinum

Process Connection: Standard PG 13.5 Thread

Electrode Connection: Single Pole Euro Connector

Temperature Range: 0° - 85°C
(32° - 185°F)

Pressure Range: 100 - 790 kPa abs
(0 - 100 psig)

Specifications subject to change without notice.

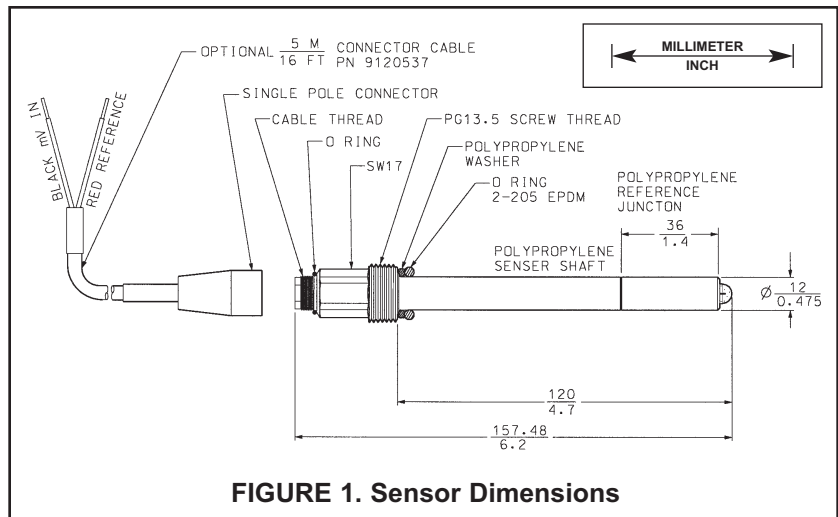

FIGURE 1. Sensor Dimensions

WARNING

BEFORE REMOVING THE SENSOR, be absolutely certain that the process pressure is reduced to 0 psig and the process temperature is lowered to a safe level!



CAUTION

SENSOR/PROCESS APPLICATION COMPATIBILITY

The wetted sensor materials may not be compatible with process composition and operating conditions. Application compatibility is entirely the responsibility of the user.

STORAGE

1. It is recommended that electrodes be stored in their original shipping containers until needed.
2. Do not store at temperatures below -5°C (23°F).
3. Electrodes should be stored with a protective cap containing KCl solution (PN 9210342).
4. For overnight storage, immerse the sensor in tap water or 4 pH buffer solution.

ELECTRODE PREPARATION

1. Remove electrode from shipping container.
2. Remove the protective boot covering the electrode bulb.

NOTE

Do not allow lubricant to coat the platinum band or reference junction. If it does, wipe it clean before installation.

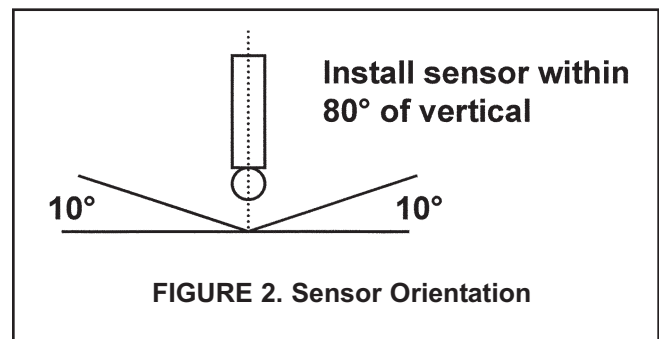

FIGURE 2. Sensor Orientation

INSTALLATION

For sensor orientation, see Figure 2.

For wiring, see Figure 3.

ORP CALIBRATION

1. After making an electrical connection between the sensor and the instrument, obtain a standard solution of saturated quinhydrone. This can also be made quite simply by adding a few crystals of quinhydrone to either pH 4 or pH 7 buffer. Quinhydrone is only slightly soluble, therefore only a few crystals will be required.
2. Immerse the sensor in the standard solution. Allow 1-2 minutes for the ORP sensor to stabilize.
3. Adjust the standardize control of the instrument to the solution value shown in the table below. The resulting potentials, measured with a clean platinum electrode and saturated KCl/AgCl reference electrode, should be within +/- 20 millivolts of the value shown in the table below. Solution temperature must be noted to ensure accurate interpretation of results. The ORP value of saturated quinhydrone solution is not stable over long periods of time. Therefore, these standards should be made up fresh each time they are used.
4. Remove the sensor from the buffer, rinse, and install in the process.

ORP of Saturated Quinhydrone Solution (millivolts)

	pH 4 Solution			pH 7 Solution		
Temp °C	20	25	30	20	25	30
mV Potential	268	264	260	94	87	80

MAINTENANCE

Electrodes should respond rapidly. Sluggishness, off-sets, and erratic readings are indicators that the electrodes may need cleaning or replacement.

1. To remove oil deposit, clean the electrode with a mild non-abrasive detergent.
2. To remove scale deposits, soak electrodes for 30 to 60 minutes in a 5% hydrochloric acid solution.
3. ORP (metallic) electrodes should be polished with moistened baking soda.

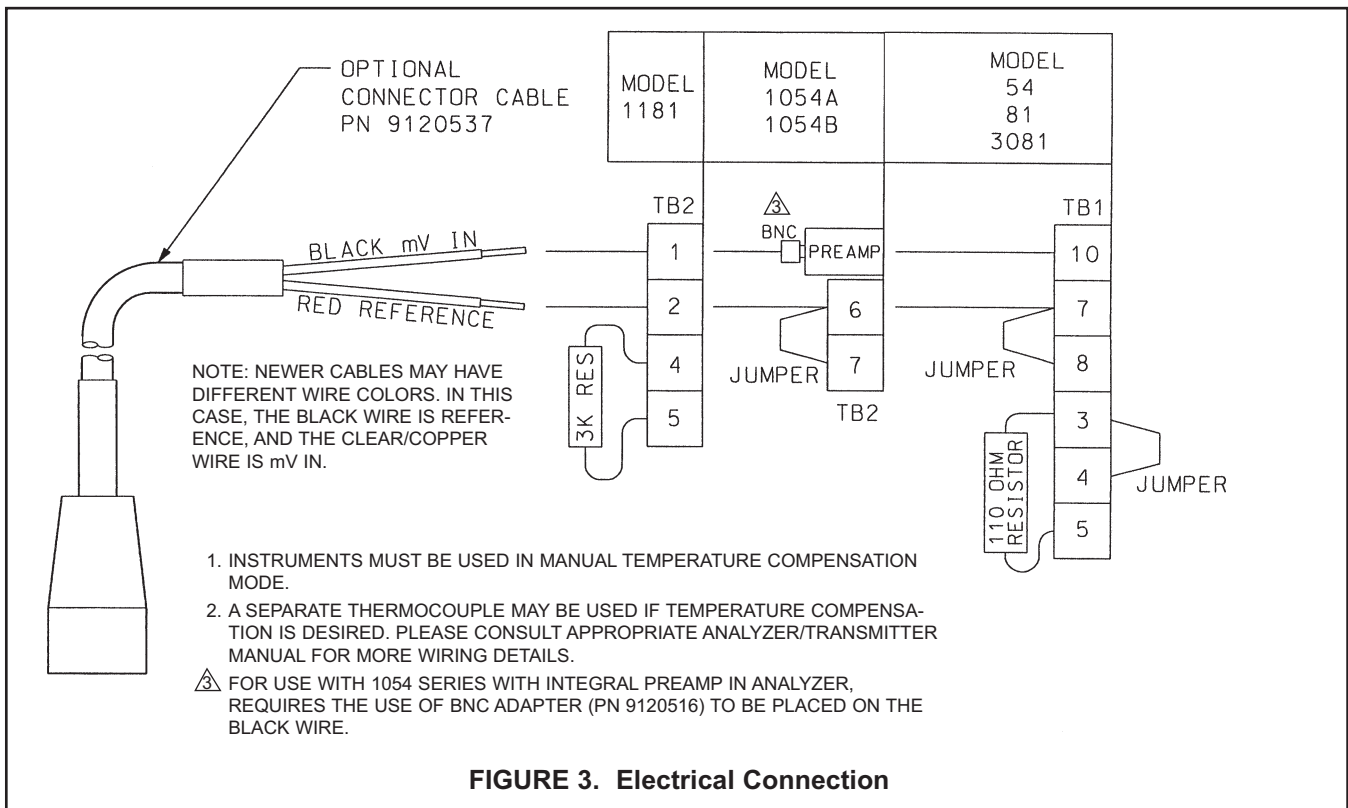

Emerson Process Management

Rosemount Analytical Inc.

2400 Barranca Parkway
Irvine, CA 92606 USA
Tel: (949) 757-8500
Fax: (949) 474-7250

<http://www.raihome.com>

© Rosemount Analytical Inc. 2005

EMERSON
Process Management