

Züllig Suspended Solids and Turbidity Measurement System COSMOS®-25

- ONE SENSOR FOR SUSPENDED SOLIDS OR TURBIDITY
- ANALYZER READOUT IN VARIOUS UNITS: g/L, %, mg/L, ppm, NTU, FNU, or EBC
- MEASURES A WIDE RANGE OF SUSPENDED SOLIDS from 0.001 to 400 g/L or TURBIDITY from 0.001 to 10,000 NTU
- SIMPLE SUSPENDED SOLIDS CALIBRATION usually with a single calibration point
- HIGH QUALITY TURBIDITY MEASUREMENT ACCORDING TO ISO 7027 and requires no calibration.
- UNIQUE SENSOR FEATURES for reliable and accurate measurements
- VERSATILE SENSOR MOUNTING OPTIONS — Submersion, Insertion, or Tri-Clamp®
- STAINLESS STEEL SENSOR HOUSING with scratch-proof sapphire windows
- OPTIONAL SELF CLEANING SENSOR with mechanical wiper mechanism



FEATURES AND APPLICATIONS

Make accurate measurements of suspended solids and turbidity with the same sensor over a wide range of measuring values. The sensor uses infrared beams which are transmitted and received to and from the measuring media. Using the latest technology, the different measuring signals are analyzed and provide a reliable and accurate reading of suspended solids or turbidity. Due to its planar measuring system and flat polished smooth sensor surface (no cams or slots), the sensor can be used in open channels, basins as well as pipelines.

APPLICATIONS

Water and Wastewater
Food and Beverage
Filtration Process
Biological Sludge Control
Water Quality
Final Effluent Monitoring

COSMOS-25 SENSOR DESIGN

The sensor housing material is stainless steel, and two infrared beams at 860 nm wave length produce a reliable and long lasting light source for making the measurement. These optics are protected from scratches and damage by scratch-resistant sapphire windows located at the tip of the sensor. The sensing surface is highly polished and smooth so that sludge and solids have no place to collect.

Infrared beams are transmitted to the media and are received back from the media through the four sapphire windows. Due to the position of the windows and the use of a pulsed light source, the measurement is not affected by window pollution, temperature fluctuations, or suspended colors. In addition, the sensor measurement is not affected by the presence of air bubbles because the sensor software compensates for this.

continued on page 2

All the electronic parts and circuitry are mounted inside the sensor for receiving and transmitting data. The compensation, verification, and calculations are performed inside the sensor and are transmitted to the analyzer via an RS485 interface. Since the calibration data is stored inside the sensor, software updates can be easily performed, and sensors and analyzers can be exchanged without re-calibration or programming.

COSMOS-25 SENSOR MOUNTING

The COSMOS-25 sensor is available in three different mounting options and can easily be used for either submersion, insertion with two different sensor lengths, or sanitary applications.

OPTIONAL SELF-CLEANING SENSOR WIPER



For difficult applications which result in excessive sensor coating, or processes with heavy greases and oils, the submersion sensor is available with an optional self-cleaning mechanical wiper system. The operation of the mechanical wiper is controlled by the analyzer and the cleaning interval can be adjusted at the analyzer. In addition, the sensor optics automatically detect a coated sensor surface condition and will operate the mechanical wiper or provide a "cleaning probe" message at the analyzer and operates below 100 NTU.



COSMOS-25 sensor for submersion (left), insertion (middle), or with integral 2-inch Tri-Clamp fitting (right).

THEORY OF OPERATION

The measurement of suspended solids and turbidity is based on light absorption technology and the principle that the intensity of incident light decreases proportionally to the concentration of the suspended solids in the medium. The Züllig suspended solids sensor has two infrared LED light sources that send a beam of light through the medium, and two emitter diodes that measure the intensity of the scattered light. Two measuring cycles are used, which provide a highly reliable measurement, and the six-channel multi-beam pulsed infrared light system (SCMPILS) compensates for errors due to fouling or aging of the light source.

The Züllig turbidity measurement also uses a combined multi-beam pulsed light system. The measurement is based on a two channel 90° scattered light principle, and meets the ISO 7027 standard. This measurement also uses two measuring cycles and an infrared LED light source.

The COSMOS-25 sensor can be used to measure suspended solids or turbidity for internal monitoring purposes or process control. If these measurements are required for compliance or governmental reporting purposes, such as for the EPA, a different measurement method may be required. Consider using Rosemount's Model T1054-2100 Series Turbidity System, which meets the EPA 180.1 standard.

CALIBRATION

The COSMOS-25 can be easily calibrated. For suspended solids measurement, most applications only require a single point calibration. After placing the sensor in the sample process, the concentration of the sample is determined by drying and weighing the solids from the sample. The concentration of the sample is then entered into the analyzer. The sensor internal optimizing routine allows for an exact duplication of the medium curve with only a few calibration points. For a medium that fluctuates, up to three calibration points can be entered, but one point is standard. Should you need to measure Turbidity, the COSMOS-25 sensor is ready to use since it is calibrated at the factory and requires no further calibration.

ANALYZER DESIGN

The Züllig analyzer is a micro-controller that includes a large display for the suspended solids and turbidity measurements. All settings can be accessed by a user-friendly menu with four membrane type keys. The compact design includes a large connection box for making field connections. Two analog 4-20 mA outputs and two relays are included.

ZÜLLIG COSMOS-25 SENSOR MODEL CO25V

GENERAL SENSOR SPECIFICATIONS

Wetted Materials: Stainless steel (316L and 329), sapphire, Viton

Measurement Media: A liquid media

Temperature (Operating): 0 - 60°C (32-140°F) without mechanical wiper

Maximum Pressure: 145 psig (10 bar) without mechanical wiper

Cable Length (Standard): 13 feet (4 m)

Maximum Cable Length: 985 ft (300 m)

Electrical Supply: 24 VDC (provided by analyzer)

Sensor Output: Digital RS 485

Electrical Current: Approximately 60 mA

Sensor Diameter: 1.58 inches (40 mm)

MECHANICAL WIPER SPECIFICATIONS (FOR SUBMERSION CODE H5 ONLY)

Wetted Materials: DuraForm™ Glass Filled and Polyurethane

Maximum Temperature: 0-50°C (32-122°F)

Maximum Pressure: 14.5 psig (1 bar)

Interval Timer: Adjustable between 20 - 90 minutes

Automatic Cleaning Cycle: Operates below 100 NTU

SUSPENDED SOLIDS SENSOR SPECIFICATIONS

Minimum Range: 0.001 g/L

Maximum Range: Limit depends on the medium

Typical: Biological sludge: >200 g/L

Digested sludge: >100 g/L

Silica dioxide (SiO₂): >400 g/L

Accuracy: Depends on the calibration methods

Typical: <5% of reading

Response Time: 1 second

TURBIDITY SENSOR SPECIFICATIONS

Minimum Range: 0.001 NTU

Maximum Range: 10,000 NTU

Accuracy: Typical <3% of reading (1-1,000 NTU range)

Repeatability: <4% of reading (1-1,000 NTU range)

Response Time: 5 - 10 seconds

SUBMERSION SENSOR (CODE H5)

Sensor Length: 59 inches (1,500 mm)

Minimum Insertion Depth (into process): 0.20 in. (5 mm)

Maximum Clearance (from bottom): 1.1875 - 3.125 in. (30 - 80 mm)

Minimum Distance From Wall: 10 in. (254 mm)

Weight/Shipping Weight: 9 lb/10 lb (3.5 kg/4 kg)

INSERTION SENSOR (CODE E5 and D5)

Sensor Length: 10.63 in (270 mm) Code E5

13.58 in (345 mm) Code D5

Minimum Insertion Depth (into process): 0.20 in (5 mm)

Maximum Clearance (from bottom): 1.1875-3.125 in (30-80 mm)

Minimum Pipe Diameter: 4 in (100 mm)

Weight/Shipping Weight: 7 lb/8 lb (3 kg/3 kg)

INTEGRAL TRI-CLAMP FITTING (CODE XL)

Sensor Length: 8.35 in (212 mm)

Minimum Pipe Diameter: 2.5625 in. (65 mm)

Tri-Clamp Size: 2 Inch

Tri-Clamp Weld Fitting: Refer to page 6

Weight/Shipping Weight: 7 lb/8 lb (3 kg/3 kg)

ZÜLLIG SUSPENDED SOLIDS & TURBIDITY ANALYZER MODEL BL5

Enclosure: NEMA 4X (IP66)

Dimensions: 7.24 X 9.33 X 3.31 (LxHxW in.)

Conduit Openings: Four chord grips

Display: LCD, 6 digits; 7 segments (readout), 6 digits 16 segments (menu)

Suspended Solids Measurement Units: g/L, %, ppm, or mg/L

Turbidity Measurement Units: NTU, FNU, or EBC

Ambient Temperature: -20 to 50°C (-4 to 122°F)

Space Heater: 9 watt electronically controlled

Relative Humidity: 90%, non condensing

Power: 115 VAC 60 Hz, 14 VA max

Input: Züllig CO25V sensor

Current Outputs: Two 4-20 mA, 0 - 20 mA, 600 ohm max load

Relays: Two

Relay Contact: 2.0 Amp Max, 115 VAC

Sensor Connections: 4 terminals

Power Connections: 3 terminals

Weight/Shipping Weight: 6 lb/7 lb (2.5 kg/3.0 kg)

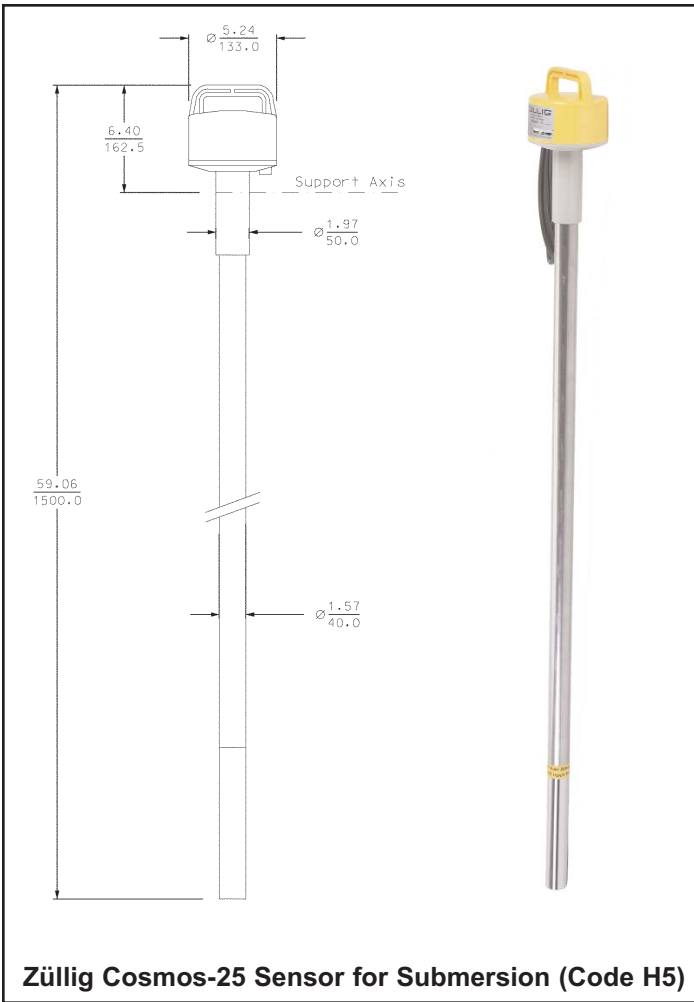

Zülig Cosmos-25 Sensor for Submersion (Code H5)

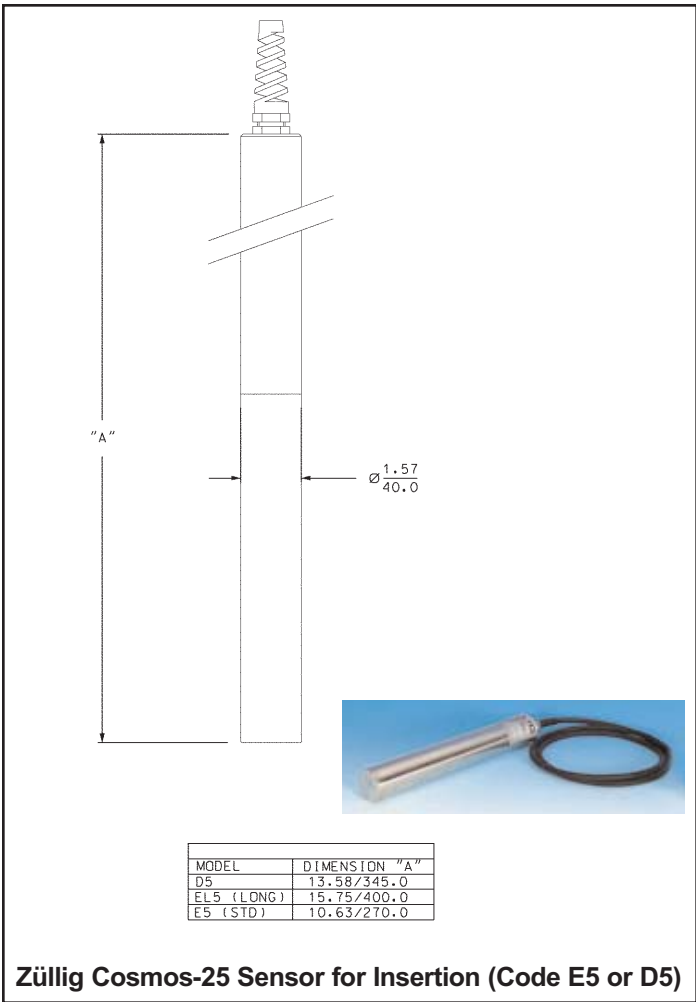

MODEL	DIMENSION "A"
D5	13.58/345.0
EL5 (LONG)	15.75/400.0
E5 (STD)	10.63/270.0

Zülig Cosmos-25 Sensor for Insertion (Code E5 or D5)

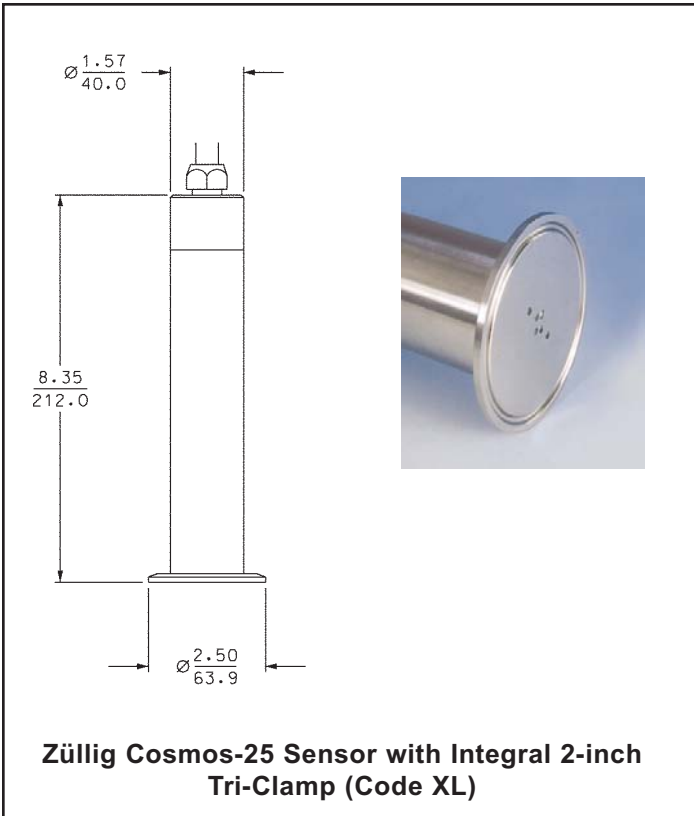

Zülig Cosmos-25 Sensor with Integral 2-inch Tri-Clamp (Code XL)

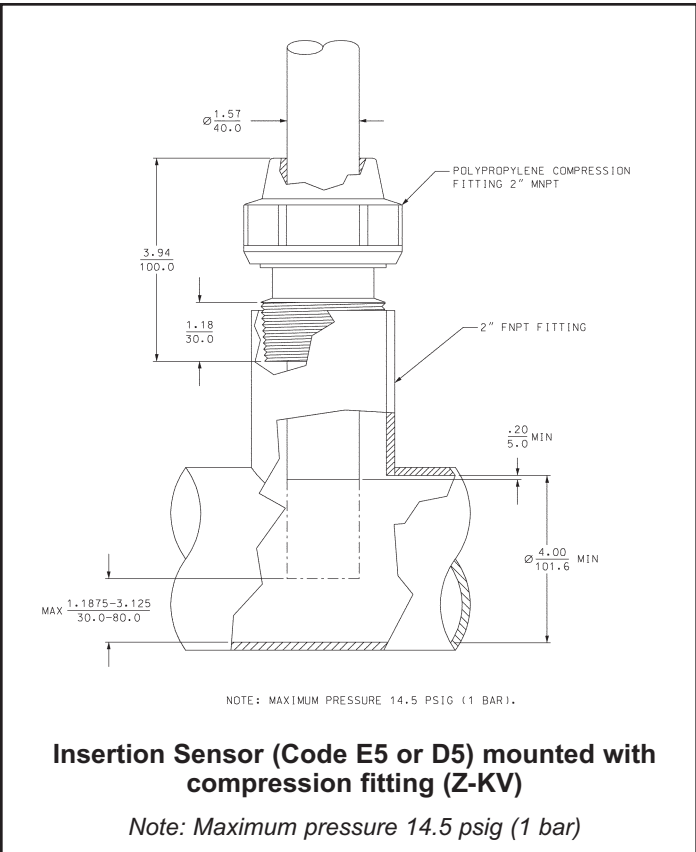

Insertion Sensor (Code E5 or D5) mounted with compression fitting (Z-KV)

Note: Maximum pressure 14.5 psig (1 bar)

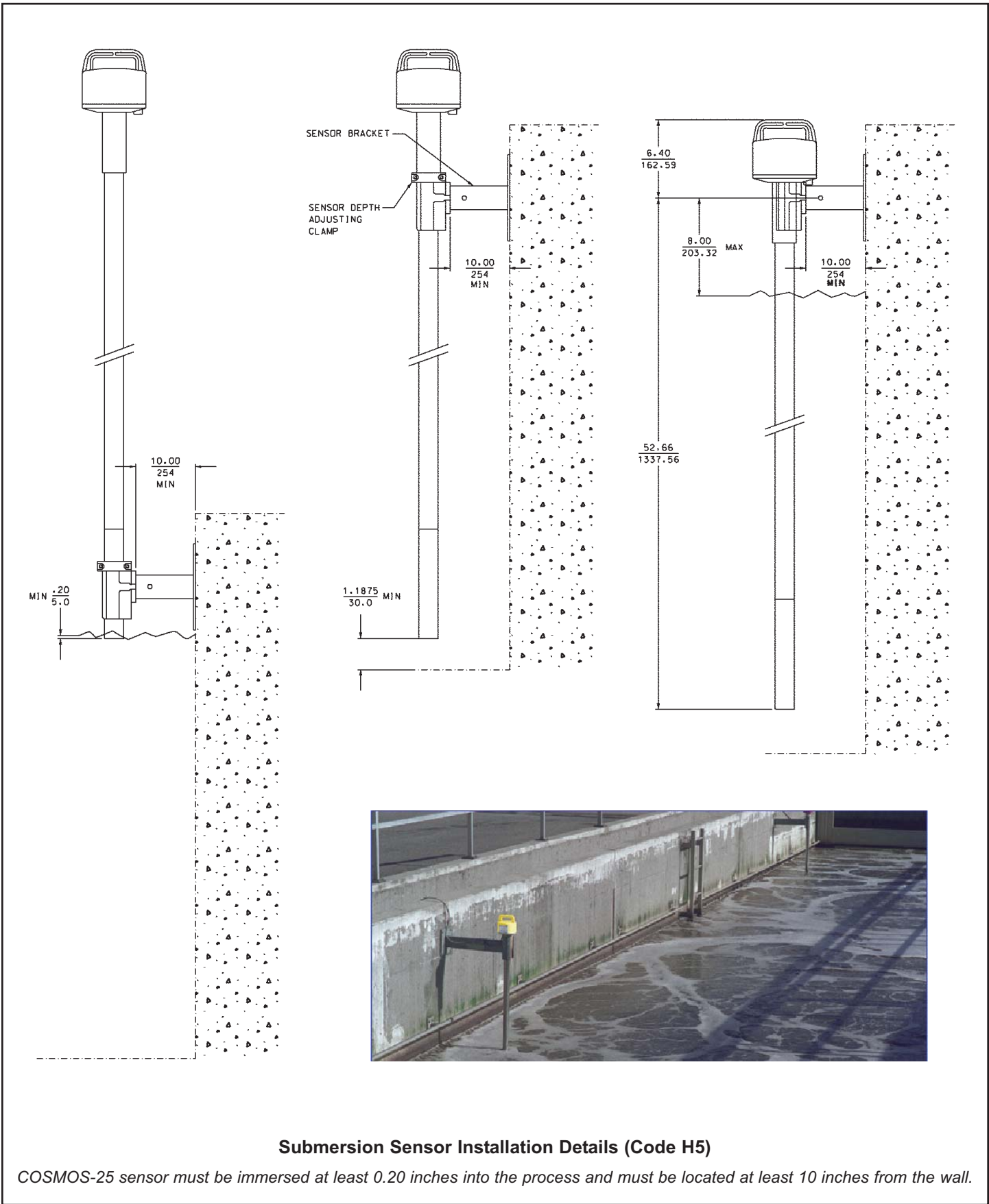

Submersion Sensor Installation Details (Code H5)

COSMOS-25 sensor must be immersed at least 0.20 inches into the process and must be located at least 10 inches from the wall.

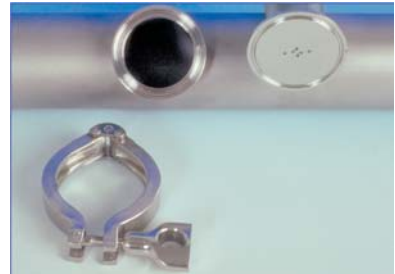
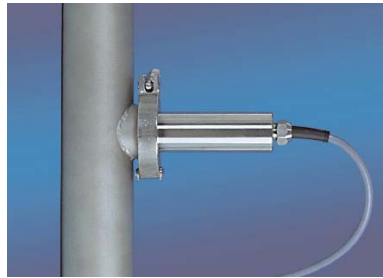
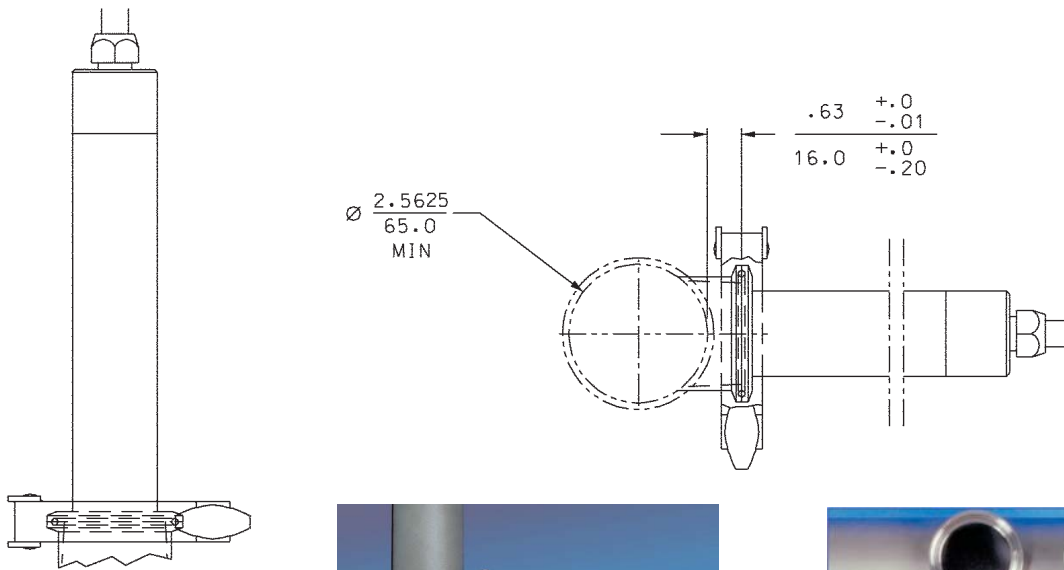

Tri-Clamp Sensor Installation Details (Code XL)

Note: 2-inch Tri-Clamp, weld fitting, and gasket provided by others.

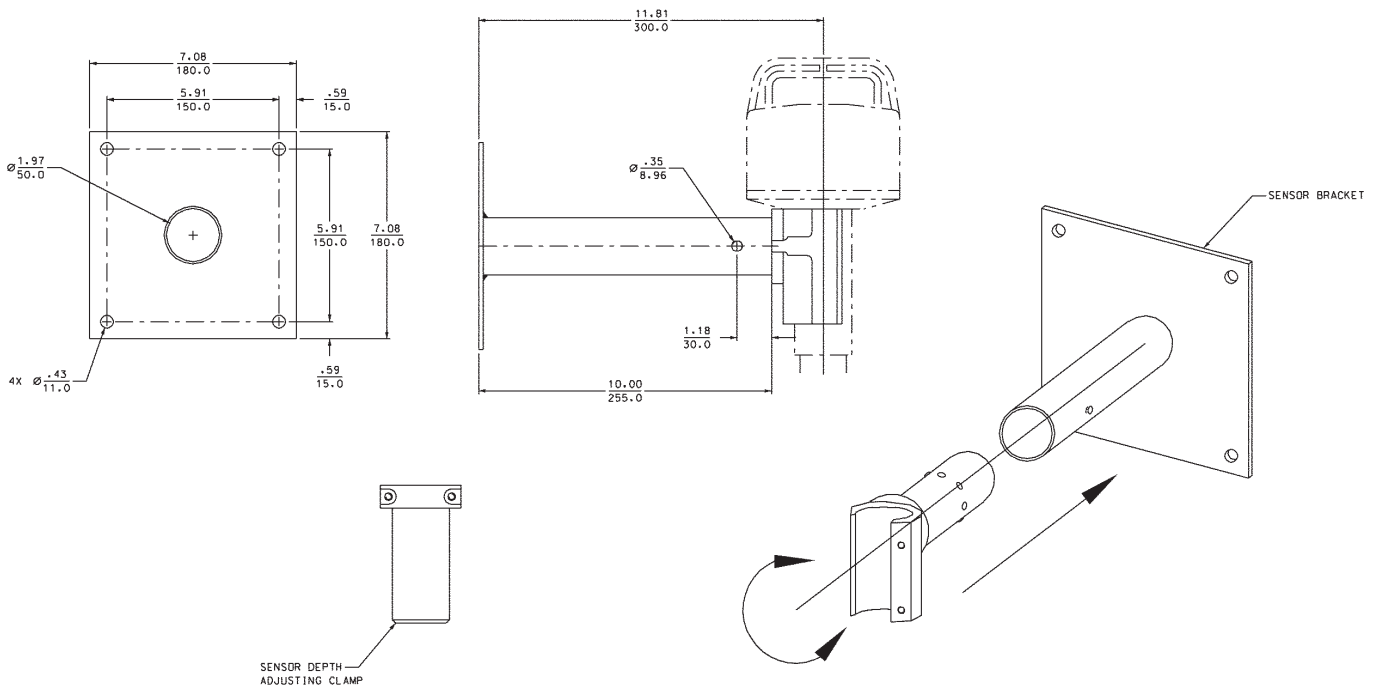

Optional Sensor Bracket and Sensor Depth Adjusting Clamp

ORDERING INFORMATION

The Züllig Suspended Solids/Turbidity System consists of a sensor measuring element and an analyzer. The sensor can be ordered for three mounting options: submersion with an optional mechanical sensor wiper, insertion in two lengths, or Tri-clamp mounting. The standard sensor cable length is 13 feet and connects directly into the analyzer. The Züllig analyzer includes two 4-20 mA outputs, and two relays. Power required is 115 VAC 60 Hz.

ANALYZER

MODEL	DESCRIPTION
BL5SSB	Cosmos-25 Suspended Solids Analyzer
BL5TMB	Cosmos-25 Turbidity Analyzer
CODE	Required Selection
V2	For use with Model CO25V Sensor

SENSOR

MODEL	DESCRIPTION
CO25V	Cosmos-25 Suspended Solids/Turbidity Sensor
CO25VW	Cosmos Suspended Solids/ Turbidity Sensor with Mechanical Sensor Wiper (available with Code H5 only)
CODE	Sensor Length (Required selection)
H5	Submersion mounting, 1500 mm (59 in.)
E5	Insertion mounting, 270 mm (10-5/8 in.)
D5	Insertion mounting, 345 mm (13-9/16 in.)
XL	Insertion mounting with integral 2-inch tri-clamp fitting, 212 mm (8-3/8 in.)

ACCESSORIES

PART #	Description
10300003	Sensor Bracket, 300 mm (11-7/8 in.)
10634	Sensor depth adjustment clamp for sensor mounting bracket (PN 10300003)
2001492	Tag Kit for analyzer or sensor, stainless steel, specify markings
Z-KV	Compression fitting for insertion sensor, 2 in. MNPT
ZAMK	Analyzer mounting kit for pipe or surface mounting with hardware

ENGINEERING SPECIFICATION - ZÜLLIG SUSPENDED SOLIDS/TURBIDITY SYSTEM

-Analyzer Model BL5-

1. The Model BL5 analyzer shall be micro-controlled based and accept a Züllig COSMOS-25 sensor model CO25V. The same sensor shall be capable of measuring both suspended solids and turbidity.
2. The analyzer shall include a diagnostics for alerting the operator of a high voltage break, no reference, no measuring signal, and a disconnected sensor.
3. The analyzer shall include an automatic log for recording the number of power-up/power-down starts, serial number, software version, and hours of operation.
4. The analyzer shall have a LCD display with 6 digits. The measuring display readout shall include 7 segments and the menu display shall include 16 segments.
5. The analyzer display shall indicate suspended solids in g/L, %, mg/L, or ppm (user selected), and turbidity in NTU, FNU, or EBC (user selected). The temperature display shall be in °C or °F (user selected). Auxiliary information shall include alarm status, menu status, hold status, simulation test mode, calibration mode, and alarm mode.
6. Calibration for suspended solids shall be accomplished by drying and weighing the sample and entering the value into the analyzer. Most applications shall require one calibration point, but up to three calibration points can be entered. Turbidity shall be calibrated by the manufacturer and require no further calibration.
7. The analyzer shall include two sets of analog outputs. Each output shall consist of 4-20 mA or 0-20 mA. Each output shall correspond to the suspended solids or turbidity measurement. The outputs shall be programmable with minimum and maximum output values.
8. The analyzer shall include two alarm relays rated for 2 amps at 115 VAC and shall be fully programmable.
9. The analyzer shall be NEMA 4X (IP66), require 115 VAC 60 Hz power, and include an onboard space heater electronically controlled.
10. The analyzer shall include a waterproof quick disconnect plug permanently wired to the analyzer to be used for the sensor cable.
11. The analyzer shall be a Rosemount Analytical Model BL5.

-Suspended Solids/Turbidity Sensor Model CO25V-

1. The sensor housing shall be stainless steel construction. The sensing surface shall be flat with no cams or slots, highly polished and smooth to resist coating and solids buildup. Scratch-resistant sapphire windows located at the sensor tip shall protect the sensor optics.

2. The sensor shall be available in three mounting options for submersion, insertion or sanitary applications with an integral 2-inch Tri-Clamp fitting.
3. The measurement shall be based on light absorption and scattered light technology and use two infrared beams at 860 nm as the light source. Infrared beams shall be transmitted into the media and received back to operate in two measuring cycles for improved reliability.
4. The six channel multi-beam pulsed infrared light system (SCMPILS) shall compensate for errors due to fouling or aging of the light source. Window pollution, temperature fluctuations, or suspended colors shall not affect the measurement.
5. The sensor software shall compensate for air bubbles present on the sensor surface and shall not affect the measurement.
6. The turbidity measurement shall be based on a two channel 90° scattered light principle and meet the ISO 7027 standard using an LED light source.
7. For submersion sensors (Code H5) an optional self-cleaning mechanical sensor wiper system shall automatically clean the sensing surface for coating applications. The sensor optics shall automatically detect a coated sensor surface and provide a "cleaning" message at the analyzer. The sensor with the mechanical wiper shall operate from 0°C to 50°C (32°F to 122°F) and a maximum pressure of 14.5 psig (1 bar).
8. The suspended solids measurement shall have a range of 0.001 to 400 g/L (limit depends on the medium) with an accuracy of less than 5% of the reading (depends on calibration methods). The turbidity measurement shall have a range of 0.001 to 10,000 NTU with an accuracy of <3% of the reading.
9. The sensor shall be capable of operating from 0°C to 60°C (32°F to 140°F) and a maximum pressure of 145 psig (10 bar) without the mechanical wiper.
10. The sensor cable length shall be 13 feet long and include a waterproof quick disconnect plug and plug directly into the analyzer disconnect plug. The maximum sensor cable length shall be 985 feet.
11. Calibration and configuration shall be stored inside the sensor, and allow for quick sensor and analyzer exchange. The sensor shall communicate to the analyzer via an RS485 digital signal.
12. The submersion sensor shall include a shaft and hood for mounting. A sensor bracket and sensor adjusting clamp shall be included to mount the sensor to the basin wall.
13. The sensor shall be Rosemount Analytical Model CO25V Code H5, E5, D5, or XL.



*The right people,
the right answers,
right now.*

ROSEMOUNT ANALYTICAL
CUSTOMER SUPPORT CENTER
1-800-854-8257



Credit Cards for U.S. Purchases Only.



ON-LINE ORDERING NOW AVAILABLE ON OUR WEB SITE
<http://www.raihome.com>

Specifications subject to change without notice.

Emerson Process Management

Liquid Division

2400 Barranca Parkway
Irvine, CA 92606 USA
Tel: (949) 757-8500
Fax: (949) 474-7250

<http://www.raihome.com>