

Flow Through pH/ORP Sensors

- CHOICE OF PVC, KYNAR¹, TEFLON², STAINLESS STEEL to handle most industrial applications.
- BUILT-IN PREAMPLIFIER provides reliable signal transmission.
- DOUBLE JUNCTION, GEL-FILLED, REFERENCE CELL provides high temperature performance, extended service life, and resists the effects of pumping, dilution and contamination.
- MINIMIZE FOULING PROBLEMS with large area reference junction and optional ultrasonic or flow powered cleaner.

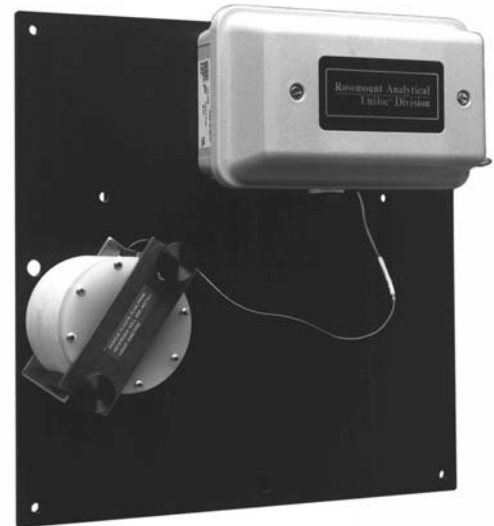

FEATURES AND APPLICATIONS

The Rosemount Analytical Model 320B pH Sensor measures the pH of a flowing aqueous fluid. Typical applications include pH monitoring or control in boiler feed water, process water, chemical processes, municipal water treatment, and many other applications. The Model 330B measures oxidation reduction potential (ORP), and has applications in chromate waste treatment, bleaching operations, chemical processes and municipal water treatment. Depending on the application, the sensor may be installed directly in the process line or in a by-pass line.

The sensor consists of a flow chamber, measuring electrode, reference electrode, temperature compensator (where applicable) and an ABS junction box containing a preamplifier.

These components are mounted on an ABS backplate which may be attached to a wall or, with selection of Code 30, clamped to a 2 inch pipe. The ABS plate is designed to allow quick and simple field installation of explosion-proof conduit (Code 90) or the ultrasonic cleaner (Code 08-70). See Figure 1 for outline and mounting dimensions.

The flow chamber contains the measuring electrode and, except for the Model 330B, an automatic temperature compensation element. The unique design electrode gland fitting allows the measuring electrode to be easily removed for maintenance or replacement. The design of this fitting

prevents overtightening of the gland nut thus preserving the integrity of the O-ring process seal. The removable reference chamber includes electrolyte and a large-area liquid junction and a double junction reference electrode. The sealed reference chamber requires no pressurization, and the large supply of saturated gel solution of KNO₃ electrolyte will last up to one year, in most applications, without refilling. This is especially useful for processes containing ferric chloride, sulfide (such as H₂S and Na₂S), cyanide, silver, lead, mercury, chlorine, sugar or ammonia.

OPTIONS

A number of options are available which adapt the sensor to a variety of uncommon applications. For installation in Class I, Division 2, Group D explosion-proof areas, Code 90 may be selected.

Code 06 features a flow-powered cleaner, with teflon balls, driven by a minimum flow of 4 GPM, to impinge on the pH measuring electrode to prevent it from coating.

Ultrasonic cleaning is another option for applications where the measuring electrode may become coated. The wave action retards or prevents the coating; turning a marginal application into a practical one. Codes 08-70 (Kynar flow and reference cell) specify this feature.

¹ A registered trademark of Elf Atochem North America, Inc.

² A registered trademark of E.I. du Pont de Nemours and Company.

PHYSICAL SPECIFICATIONS

Materials of Construction:

Mounting Plate & Preamp Enclosure: ABS
 Materials: (with options, choice of)
 Kynar, Teflon, Stainless steel, CPVC (flow
 powered cleaner)

Electrical Classification: Standard: General purpose
 Code 90: Class I, Division 2, Group D

Process Connections: 1/2 in. MNPT, 1 in. MNPT

Mounting: Standard: Wall mount
 Code 30: 2 in. pipe mounting bracket

Measuring Electrode and Range: ACCUGLASS™¹ glass
 electrodes, 0-14 pH or
 Platinum ORP electrode -1500 to 1500 mV

Minimum Conductivity: 75 µs/cm, nominal 100 µs/cm

Temperature Compensation: Automatic, 0 to 100°C (32 to
 212°F), Plug supplied for 330B when used with
 1181ORP, 1060 or 1023

Pressure/Temperature Rating: (See Figure 3)

Interconnecting Cable:
 Cable, P/N 9200000 (Belden 8722)

Weight/Shipping Weight: 2.72 kg/3.63 kg (6 lb/8 lb)

¹ A trademark of Rosemount Analytical.



MODEL 320B/03 pH SENSOR

Percent Linearity Over pH Range		
	Option 10 & 12*	Option 11
0-2 pH	97%	94%
2-12 pH	99%	97%
12-13 pH	96%	98%
13-14 pH	92%	98%

* Note: Ruggedized glass electrodes are ideal for abrasive applications, but response times are typically slower than other glass formulas.

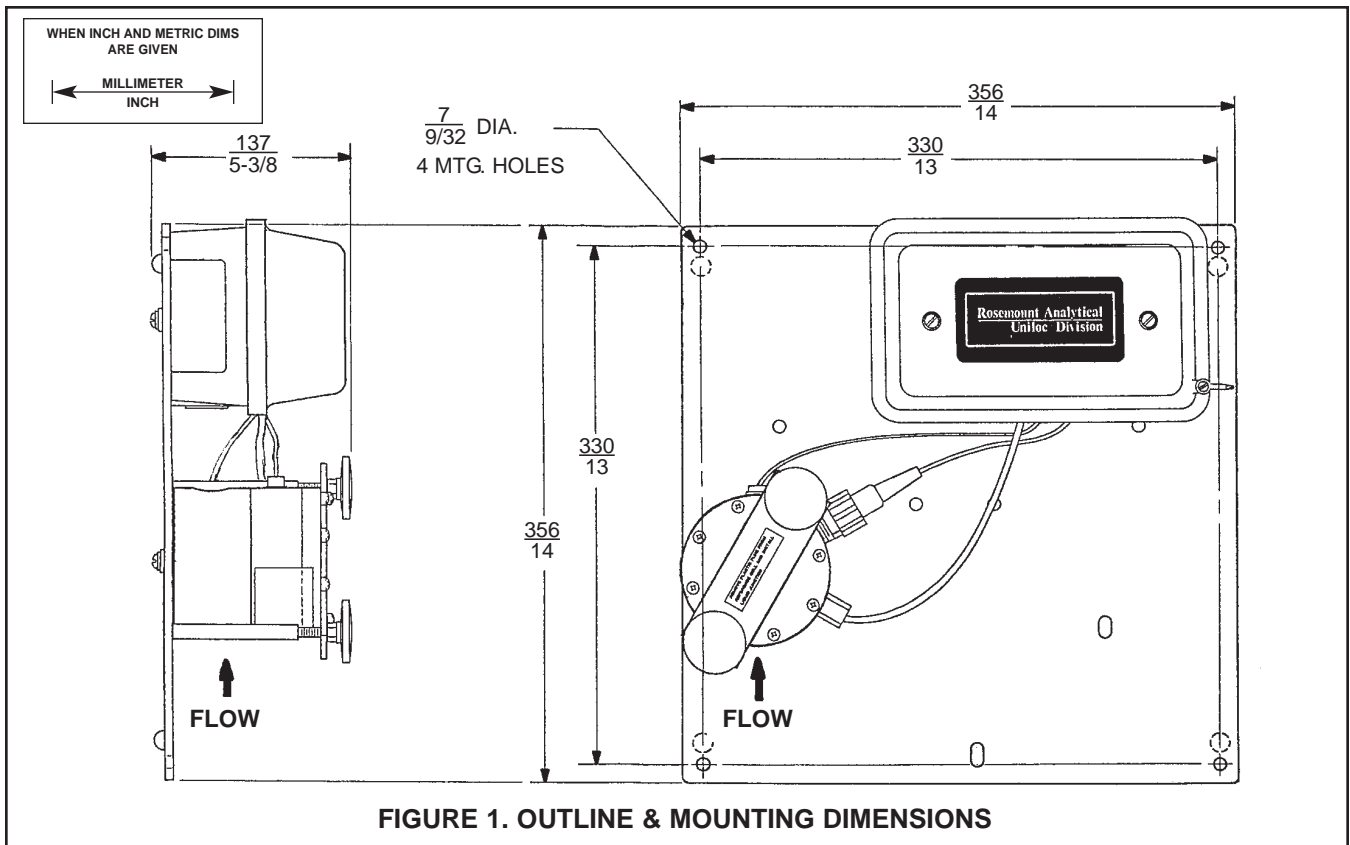

FIGURE 1. OUTLINE & MOUNTING DIMENSIONS

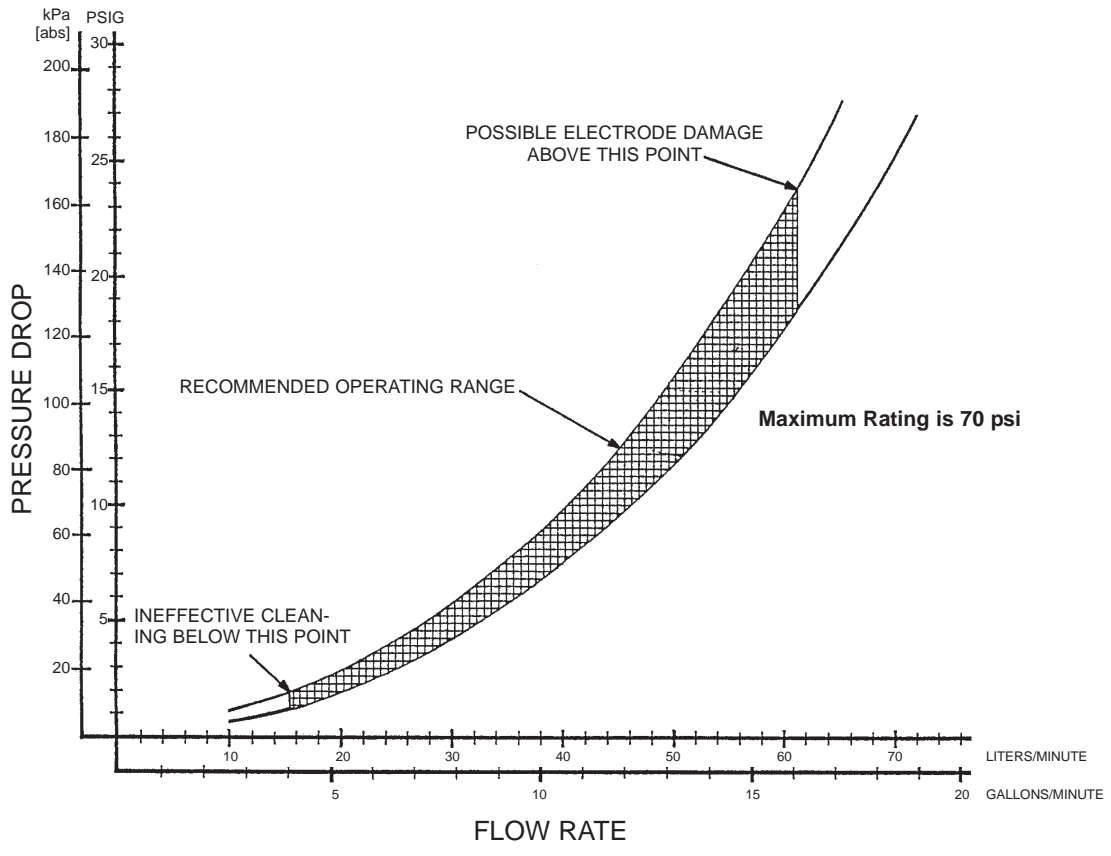

FIGURE 2. Recommended Flow Rates Flow Powered Cleaner (Code 06)

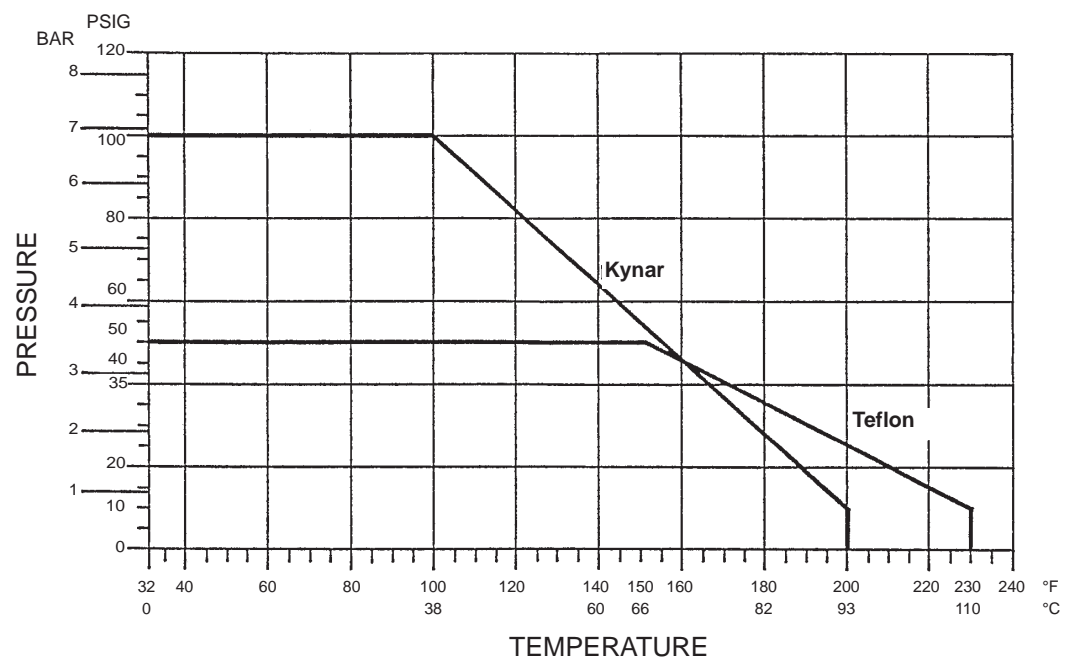

FIGURE 3. Sensor Pressure/Temperature Ratings

ORDERING INFORMATION

The Model 320B Flow Through pH Sensor: Standard features include measurement electrode, double-junction reference cell, temperature compensator and preamplifier housed in a weatherproof junction box, mounted on an ABS plate.

The Model 330B Flow Through ORP Sensor: Standard features include platinum ORP electrode, double-junction reference cell, and preamplifier housed in a weatherproof junction box, mounted on an ABS plate.

MODEL	
320B	FLOW THROUGH pH SENSOR ¹
330B	FLOW THROUGH ORP SENSOR ²
CODE	MATERIALS OF CONSTRUCTION (Required Selection)
01	Kynar 1/2 in. FNPT process connections
03	Teflon 1/2 in. FNPT process connections
05	316 SS, 1 in. FNPT process connections & Teflon reference cell (Not available for 330B)
06	CPVC flow powered cleaner, 1 in. MNPT and Kynar reference cell
08-70	Kynar 1/2 in. FNPT process connections and ultrasonic cleaner (Not available for 330B)
CODE	MEASURING ELECTRODE (Required Selection)
10	General Purpose pH
11	High pH
12	Ruggedized pH
13	Platinum ORP
CODE	PREAMPLIFIER AND TEMPERATURE SENSOR (Required Selection)
50	For use with Models 1181 pH/ORP
52	For use with remote preamplifier for Models 1181 (includes 15 ft of coax cable)
53	For use with remote preamplifier (includes 15 ft of coax cable) for Models 1054 Series, 2054, 2081
54	For use with Models 1054/A/B, 2054, 2081
CODE	OPTIONS
90	Division 2 enclosure for preamplifier (not available with 320B+)
320B	01 10 50 20 EXAMPLE

- NOTES:**
1. Interconnecting cable is required as follows: Specify length. P/N 9200000 (Belden 8722).
 2. Model 330B: Not available with Codes 05, 06, 08-70, 10, 11, 12. Model 330B: Temperature sensor not included with option 50, or 52.

ACCESSORIES

PN	DESCRIPTION
2000648	Liquid Junction, Teflon/Ceramic (formerly Code -21)
2000735	Liquid Junction, Kynar/Ceramic (formerly Code -20)
2001492	Tag, Stainless Steel, specify marking (formerly Code -40)
2001815	Pipe Mounting Bracket (formerly Code -30)



*The right people,
the right answers,
right now.*

**ROSEMOUNT ANALYTICAL
CUSTOMER SUPPORT CENTER
1-800-854-8257**



ON-LINE ORDERING NOW AVAILABLE ON OUR WEB SITE
<http://www.raihome.com>



Credit Cards for U.S. Purchases Only.



Emerson Process Management

Rosemount Analytical Inc.

2400 Barranca Parkway
Irvine, CA 92606 USA
Tel: (949) 757-8500
Fax: (949) 474-7250

<http://www.raihome.com>

